

Logimove



Logimove 1500-Transport Electric Pallet Truck

- Improved new plug-in & out Li-Ion battery
- Smart lithium battery
- Newly designed handle head
- Pass market tests of safety and reliability

Feature

Improved new plug-in & out Li-Ion battery

Improved new plug-in&out Li-Ion battery to replace the old one.

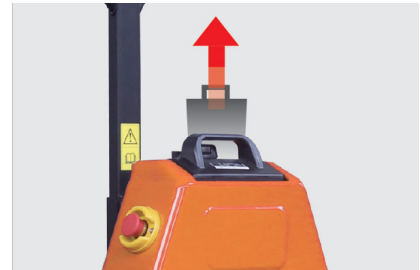

Smart Lithium Battery

EPL1531 features a 24V/20Ah li-ion plug & play battery and an external battery as standard to cope with different working shifts need.



Newly Designed Handle Head

It is lifted by electricity and lowered manually, there is no need to worry about damaging goods by uncontrollable lowering.



Pass Market Tests Of Safety And Reliability

It has 10-year market-tested components.



Standard



Option (with caster wheels)



Logimove1500-Transport

Electric Pallet Truck

Distinguishing mark	1.1	Manufacturer			Logimove
	1.2	Model designation			Logimove1500 - Transport
	1.3	Drive			Electric
	1.4	Operator type			Pedestrian
	1.5	Load capacity	q	kg	1500
	1.6	Load center distance	c	mm	600
	1.8	Load distance centre of drive axle to fork	x	mm	950 (880)
	1.9	Wheelbase	y	mm	1190 (1120)
	Service Weight	2.1	Service weight		kg
2.2		Axle loading, laden front/rear		kg	480/1140
2.3		Axle loading, unladen front/rear		kg	90/30
Tyres/chassis	3.1	Tyre type			Polyurethane
	3.2.1	Tyre size, front		mm	Φ210 x 70
	3.3.1	Tyre size, rear		mm	Φ80 x 60 (Φ74 x 88)
	3.4	Additional wheels (castor wheels)		mm	-
	3.5	Wheels, number front/rear (x=drive wheels)		mm	1x/4 (1x/2)
	3.6.1	Tread width, front	b10	mm	-
	3.7.1	Tread width, rear	b11	mm	410/(535)
Dimensions	4.4	Lift height	h3	mm	115
	4.9	Height of tiller handle in drive position min./max.	h14	mm	750/1190
	4.15	Lowered height	h13	mm	80
	4.19	Overall length	l1	mm	1540
	4.20	Length to face of forks	l2	mm	400
	4.21	Overall width	b1/b2	mm	560 (685)
	4.22	Fork dimensions	s/e/l	mm	50 x 150 x 1150
	4.25	Distance between fork-arms	b5	mm	560 (685)
	4.32	Ground clearance, center of wheelbase	m2	mm	30
	4.34.1	Aisle width pallets 1000 x 1200 crossway	Ast	mm	2145
	4.34.2	Aisle width pallets 800 x 1200 crossway	Ast	mm	2050
4.35	Turning radius	Wa	mm	1330	
Performance data	5.1	Travel speed, laden/unladen		km/h	4.5/5.0
	5.2	Lifting speed, laden/unladen		m/s	0.017/0.020
	5.3	Lowering speed, laden/unladen		m/s	0.09/0.06
	5.8	Max. gradeability, laden/unladen		%	6/16
	5.10	Service brake			Electromagnetic
Electric-engine	6.1	Drive motor rating S2 60 min		kw	0.75
	6.2	Lift motor rating at S3 15%		kw	0.7
	6.4	Battery voltage/nominal capacity		V/ah	24/20
	6.5	Battery weight			7
Addition data	8.1	Type of drive control			DC
	10.5	Steering design			Mechanical
	10.7	Sound pressure level at the driver's ear		dB(A)	<74

If there are improvements of technical parameters or configurations, no further notice will be given.
The diagram shown may contain non-standard configurations.

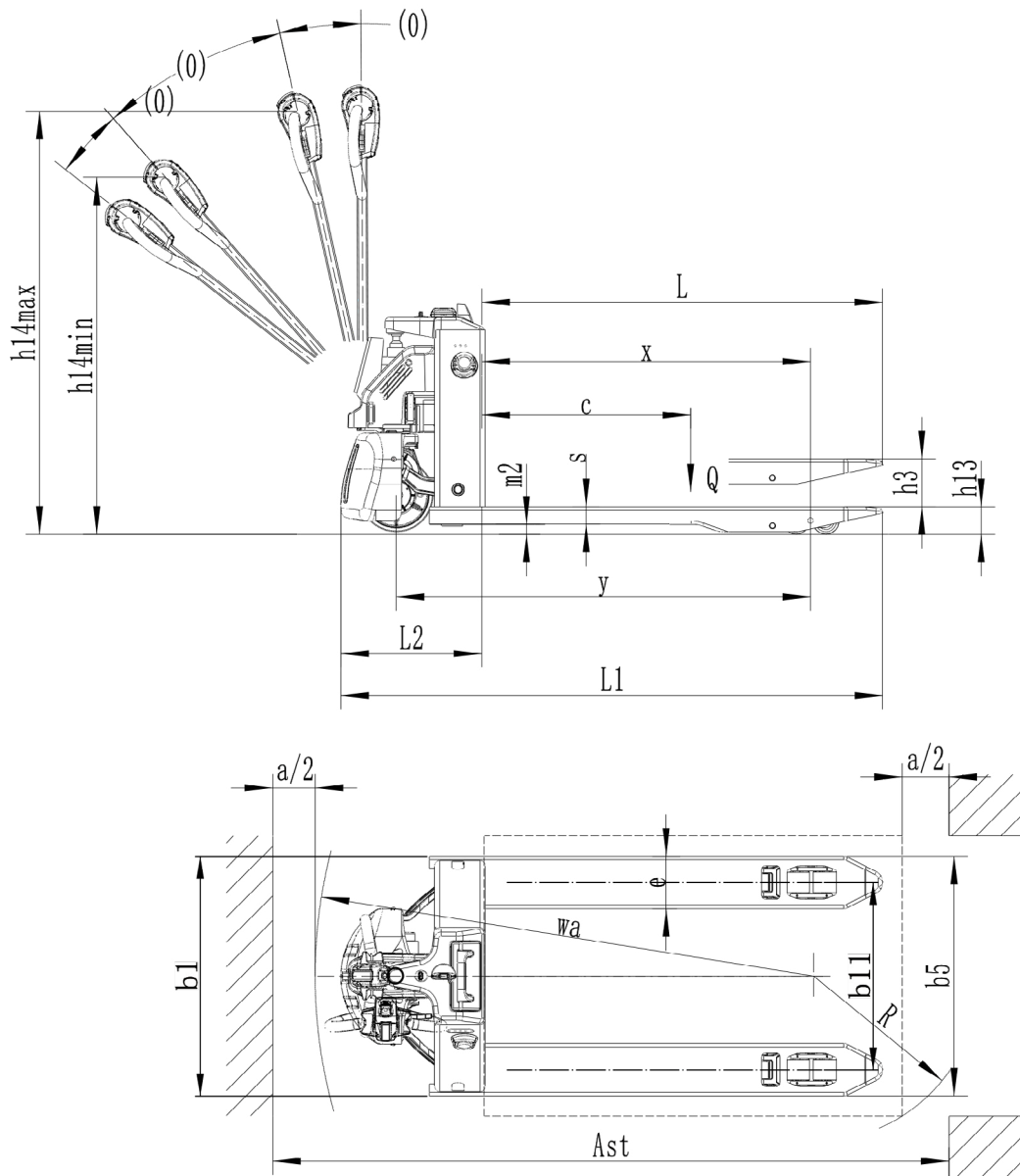

Option

No.	Option items	Logimove1500 - Transport
1.1	Fork length	● 1070 / ○ 900 / ○ 1000 / ○ 1220 / ○ 1500
1.2	Fork width	● 560 / ○ 685
1.3	Fork lowered height	● 80
2.1	Load wheel type	● Double / ○ Single
2.2	Load wheel material	● PU
2.3	Drive wheel material	● PU / ○ Trace PU
2.7	Battery capacity	● 24V/20Ah
2.8	Charger	● 24V-10A External
3.3	Castor wheels	○
3.12	Hummer	●
3.16	Vertical handler working	●

Note ● Standard ○ Optional - Inconformity



www.sitecraft.net.au | 1300 363 152 | sales@sitecraft.com.au